

A9 Dualling Dalraddy to Slochd

Stage 2 Scheme
Assessment Report
Volume 1 – (Part 4)
October 2016



Part 4: Traffic and Economic Assessment

20. Traffic and Transport Assessment

20.1. Overview

- 20.1.1. This section of the DMRB Stage 2 Report for Dalraddy to Slochd describes the existing local traffic issues, as well as proposed traffic network changes and the traffic modelling undertaken to assess their impact; the use of the modelling data to inform the economic assessment of this section of the A9 Dualling Programme is also described. Traffic modelling data was also provided to support the air quality and noise assessments that are presented in Part 3 of this report.
- 20.1.2. A Case for Investment (CFI) has been developed for the complete A9 Dualling Programme from Perth to Inverness. The analysis to support the CFI has been undertaken and reported by Aecom, Transport Scotland's CFI consultants.
- 20.1.3. This section considers the following traffic and economic issues:
- Existing traffic conditions on the A9 from Dalraddy to Slochd;
 - Traffic and access issues arising from A9 Dalraddy to Slochd Dualling;
 - Dalraddy to Slochd dualling project junction options; and
 - Forecast future modelled traffic conditions on the A9 from Dalraddy to Slochd.
- 20.1.4. The economic analysis described in this section of the DMRB Stage 2 Report has been undertaken only to assess which of the Dalraddy to Slochd scheme options performs best from a traffic and transport perspective. It is not designed to underpin the financial justification for the dualling of the Dalraddy to Slochd section, since the dualling between Perth and Inverness is being considered as a single programme of works.

20.2. Existing Transport Situation

Existing Network

Full Section

- 20.2.1. The existing transport network around the Dalraddy to Slochd section of the A9 Dualling Programme is shown in **Figure 20-1**. Existing at-grade junctions along the single carriageway are shown while other key transport routes, including the adjacent Highland Main Line railway, are also marked.
- 20.2.2. The Dalraddy to Slochd section of the A9 has a number of existing at-grade junctions that provide local access. For the majority of its length, this section of the A9 has a parallel route to the east which provides local access around Aviemore and Carrbridge.

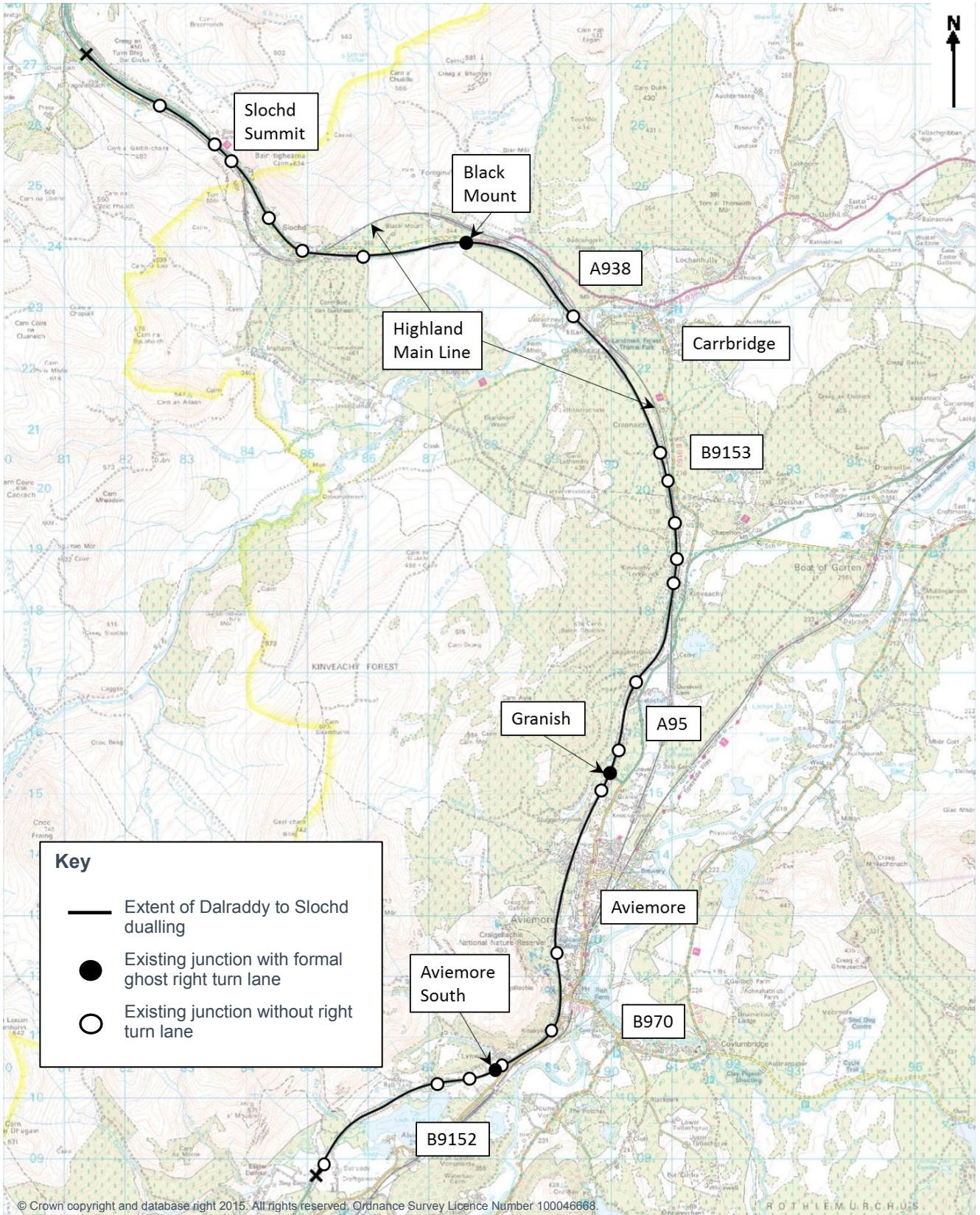

© Crown copyright and database right 2015. All rights reserved. Ordnance Survey Licence Number 100046668.

Figure 20-1 – Transport Network and Existing At-Grade Junctions between Dalraddy and Slochd South of Aviemore

20.2.3. The B9152, from Kinraig, south of Dalraddy, forms a route parallel to the A9 south of Aviemore and has a link with the A9 at the Aviemore South junction. The B970 leads east to the ski slopes, the Cairngorm Mountain Railway and other significant tourist



attractions within the National Park. The B9152 continues north through Aviemore as the town's main through route; the current A9 bypasses Aviemore around its western side.

North of Aviemore

- 20.2.4. The Granish junction north of Aviemore links the A9 with the A95 trunk road, which in turn joins the A96 at Keith and the A98 at Banff. The Granish junction also provides access between the A9 north and Aviemore via the B9152, as well as between the A9 south and Carrbridge via the B9153. The A95, Highland main line and A9 are parallel to each other for a distance of approximately 4km north of Granish junction before the A95 diverges towards the north east.

Carrbridge

- 20.2.5. Carrbridge is accessed from the south via the Granish junction and from the north from Black Mount junction. In addition, a local access junction exists on the A9 to the north west of Carrbridge at Dalrachney Beag; this junction is an at-grade crossroads. While no ghost island exists here, there is a narrow central hatching which provides some protection for right turning vehicles.

- 20.2.6. The Black Mount junction, is located approximately 3.5km northwest of Carrbridge and links the A938 and A9. The junction has a ghost island right turn lane and the A938 continues east past Carrbridge to link up with the A95 at Dulnain Bridge, west of Grantown-on-Spey. An unclassified road leaves the A938 close to the A9 and is aligned parallel to the A9 between Black Mount and Slochd.

Slochd

- 20.2.7. At Slochd, there is a priority junction with right turn lane on the A9. The minor arm of this junction is an unclassified road which provides access to the small settlement at Slochd, and then links back to the Black Mount junction, with the A9 crossing over this road and adjacent railway on a viaduct.

Existing Traffic Patterns

Traffic Data Collection

- 20.2.8. In order to inform the traffic modelling, junction sifting, stakeholder consultation and design process, traffic surveys have previously been carried out at a number of junctions along the Dalraddy to Slochd corridor, including on roads parallel to the A9. As well as underpinning the traffic modelling, the traffic data collection has provided a deeper understanding of the impact of the scheme on local traffic movements that would not be possible using the traffic model data alone.
- 20.2.9. All junction surveys were carried out from 0700 to 1900 on single days, although not all junctions were surveyed on the same day. The daily weekday flows observed during these surveys are shown in **Figure 20-2**. Whilst the flows are single day observations, they give an indication of typical traffic levels in the corridor. There will undoubtedly be busier days and quieter days, but given the impact of tourism and weather it would be challenging to seek to gather a full range of flows. The data is considered to be adequate for the purposes of assessing the relative importance of junctions and the pattern of traffic in the corridor.

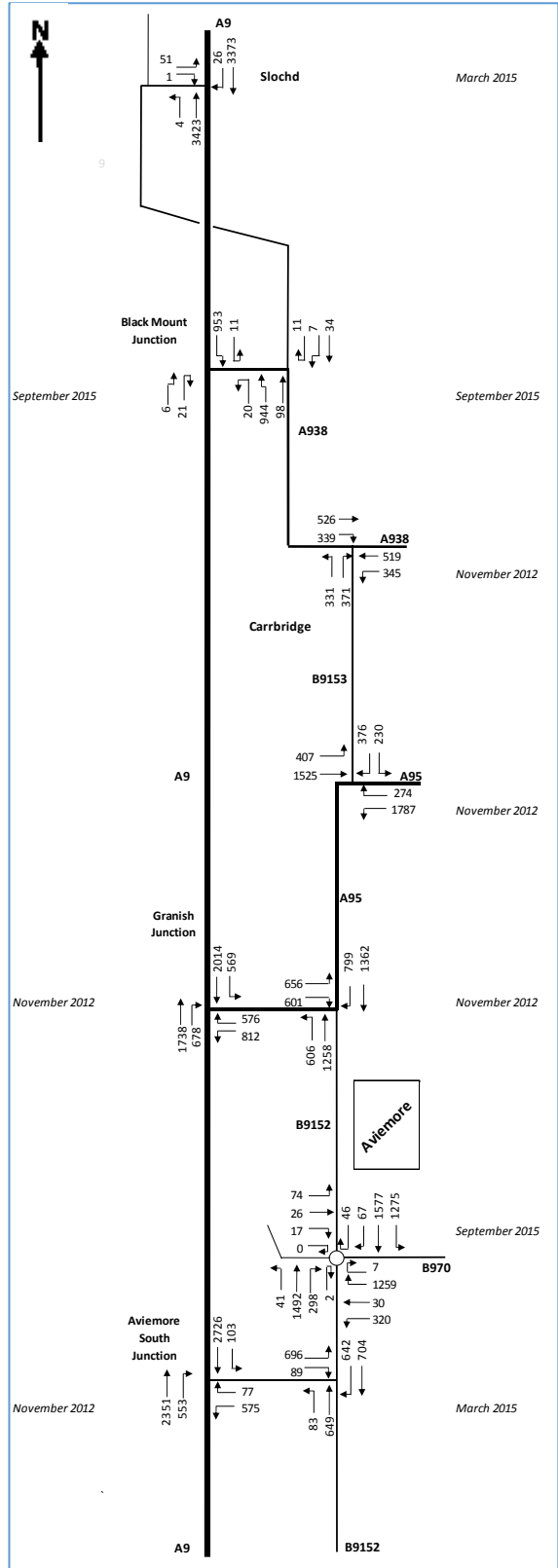

Notes:

1. The diagram does not show all junctions / accesses.
2. Flows shown are weekday 12 hours flows (07:00 to 19:00).
3. Through traffic flows on the A9 were only collected at key junctions.
4. Survey dates are shown in italics.
5. Mainline flow differences reflect the different survey years and seasonal variation.
6. The data should be treated as showing the order of magnitude and relative volumes of turning movements at each location.

Figure 20-2 Surveyed Daily Junction Turning Flows



20.2.10. From an examination of the turning traffic flows, a number of key conclusions can be drawn:

- Fewer than 100 vehicles in total turn on or off the A9 at Slochd;
- At Black Mount junction very few vehicles turn to or from the A9 south onto the A938, but approaching 1,000 vehicles join or leave the A9 north per day;
- In Carrbridge approximately 40% of traffic (~670 vehicles) on the A938 to / from Black Mount turns to / from the B9153;
- Over 75% of traffic (~3,300 vehicles) on the A95 north of Granish is longer-distance traffic from east of Carrbridge, with the remaining 25% joining and leaving at the B9153 junction near Kinveachy;
- Approximately 35% of traffic (~1,450 vehicles) on the A95 between Aviemore and Kinveachy joins or leaves the A9 at Granish;
- At the junction between the A95 and B9152 east of Granish the dominant flows are between the A95 (north) and the B9152. Although there are significant movements between the A9 and both the A95 and B9152 the pattern of movements clearly establishes the A95 (north) to / from the B9152 as the through movement at the junction;
- Slightly more traffic leaves or joins the A9 south at Granish than leaves or joins A9 north and less than 50% (~1,200 vehicles) turns to or from Aviemore; and
- At Aviemore South, 80% of traffic (~1,130 vehicles) leaving and joining the A9 does so from A9 south, and most of that traffic turns to and from Aviemore and the B970.

20.2.11. From these conclusions it is clear that the two Aviemore junctions both have significant turning traffic movements, although turns to and from the north at Aviemore South are relatively low. At Black Mount, very little traffic uses the A9 to the south.

20.2.12. This data for existing traffic was used to inform the junction sifting exercise that was carried out prior to completion of Stage 2. This junction sifting is summarised in Chapter 3 of this report. The traffic information has also assisted in traffic model validation and this is discussed later in this chapter.

Future Development Traffic

Planned New Developments

20.2.13. A number of developments, or other sources of increased vehicular activity, are expected at sites in the vicinity of the Dalraddy to Slochd dualling project. These sites are either allocated for development or have recently received planning consent and can thus be expected to increase traffic levels in the area. These developments include:

- Approximately 400 residential dwellings across various sites in the Aviemore area;
- Approximately 200 residential dwellings across various sites in the Carrbridge area;
- Budget hotel in Aviemore town centre;
- Supermarket Site in Aviemore;
- Aviemore Highland Resort; and

- A number of small infill commercial development sites across Carrbridge & Aviemore.

20.2.14. There is no land currently allocated for development in the Cairngorms National Park.

20.2.15. A more detailed summary of these planned and potential developments is provided in Chapter 8 of this report.

Traffic Impact of New Developments

20.2.16. Whilst vehicle access will need to be provided for trips associated with these new developments, their location is such that additional traffic will be able to easily access the A9 at the identified key junction locations. Future traffic growth associated with these developments is reflected in the growth assumptions in the TMfS modelling.

20.3. Route Alignment Options

20.3.1. The route alignment options for Dalraddy to Slochd are defined in Part 1 (Chapter 5) of this report. They can be summarised as:

- Mainline Option 1 - Widening predominantly on the southbound carriageway side (southbound widening);
- Mainline Option 2 - Widening predominantly on the northbound carriageway side (northbound widening); and
- Mainline Option 1a - Widening predominantly on the southbound carriageway side, with hybrid solution at south end to avoid properties (hybrid widening option).

20.3.2. The three alignment options relate to relatively minor variations in horizontal and vertical alignment that do not significantly affect route lengths, gradients or vehicle speeds.

20.4. Junction Options

20.4.1. The junction options were previously described in Part 1 (Chapter 5) of this report and these resulted from an extensive junction sifting exercise. At Granish and Black Mount, there are two variants of each layout option to accommodate the two widening options at these locations; at Aviemore South only southbound widening is being considered and therefore no variations in options are required.

20.4.2. The sifted junction locations and layout options in these locations are summarised below. The junction layouts were described in detail in Part 1 (Chapter 3).

Aviemore South

- A02 - Half Cloverleaf Interchange (Quadrants 1 & 4);
- A09- Diamond Interchange (Left-Right Stagger with Ghost Island); and
- A18 – Diamond Interchange with B9152 Realigned.

Granish

- C18 & C31 Diamond Interchange (Left-Right Stagger); and
- C21 & C34 Half Dumbbell & Cloverleaf Interchange.

Black Mount

- D02 & D12 Diamond Interchange (Left-Right Stagger);
- D13 & D03 Half Diamond (restricted access with north-facing slips only); and
- D07 & D51 Half Cloverleaf (Quadrants 2 & 4).

20.4.3. **Table 20-1** summarises the resulting 18 junction combinations for each mainline alignment option. These 18 combinations of junction layout are the same for all three alignment options, however individual junction layout references are provided for the southbound widening option only.

Table 20-1 Summary of Dalraddy to Slochd Junction Combinations

Traffic Model Option	Junction Layout Combinations (based on Option 1 - southbound widening)							
	Aviemore South			Granish		Blackmount		
	A02	A09	A18	C31	C34	D12	D03	D51
Option TR01	✓			✓		✓		
Option TR02	✓			✓				✓
Option TR03	✓			✓			✓	
Option TR04		✓		✓		✓		
Option TR05		✓		✓				✓
Option TR06		✓		✓			✓	
Option TR07			✓	✓		✓		
Option TR08			✓	✓				✓
Option TR09			✓	✓			✓	
Option TR10	✓				✓	✓		
Option TR11	✓				✓			✓
Option TR12	✓				✓		✓	
Option TR13		✓			✓	✓		
Option TR14		✓			✓			✓
Option TR15		✓			✓		✓	
Option TR16			✓		✓	✓		
Option TR17			✓		✓			✓
Option TR18			✓		✓		✓	

20.4.4. If all three alignment options are considered, there are a total of 54 options.

20.4.5. The junction combinations above exclude impacts of the A9 dualling on local accesses. These are considered, briefly in the following paragraphs.

20.5. Local Access

20.5.1. There are a number of minor accesses along the A9 which will be closed as part of the A9 dualling. Detailed consideration of these accesses will be undertaken as part of the Stage 3 assessment, however in some locations alternative provision can be incorporated into the new grade separated junctions.

20.5.2. The traffic modelling undertaken for this Stage 2 assessment has not considered these minor access movements, as the A9 strategic modelling does not provide this level of detail. Provision of alternative access to and from the local road network is however

unlikely to affect the outcomes of the assessment, as daily traffic flows on these minor accesses are very low.

20.6. Approach to Traffic Modelling

A9 Programme Case for Investment

- 20.6.1. For DMRB Stage 2, the CFI modelling and traffic forecasting is underpinned by the Transport Model for Scotland (TMfS:12) and the A9 Dualling Traffic Model (A9DTM12). The TMfS:12 is a national multimodal strategic traffic model with a base year of 2012. TMfS:12 provides strategic outputs, such as long distance inter-urban re-routing effects and strategic effects on A9 traffic of national infrastructure schemes.
- 20.6.2. The A9DTM12 is a corridor-long S-Paramics traffic micro-simulation model covering the A9 from Inveralmond Roundabout on the outskirts of Perth to north of Moy. The A9DTM12 model includes the A9 and all major junctions with A and B class roads, as well as sections of key feeder and parallel routes such as the A889 and A95.

Dalraddy to Slochd Traffic Modelling

- 20.6.3. In addition to the CFI traffic modelling, modelling of the Dalraddy to Slochd section of the A9 has been undertaken by the AMJV to feed into the assessment and design of the Dalraddy to Slochd section. This modelling has been undertaken using the A9DTM12, corridor S-Paramics model. The model has been used to assess more localised traffic effects of the project as a means of informing the environmental assessment, described in preceding sections of this report, and the economic assessment described in the next chapter. This has been done following the guidance set out in LTEA Technical Note 07 (“DMRB Stage 2 Approach to Transport Modelling and Appraisal”) jointly developed by traffic and economics specialists from Transport Scotland, Aecom, Jacobs, the CFJV and the AMJV and issued by Aecom in their role as the CFI consultant.
- 20.6.4. The three mainline alignment options are so similar that they can be considered identical for traffic modelling and operational traffic issues, since any effects on journey times from alignments that differ by only a few metres in horizontal or vertical alignment are too marginal to affect model results. Accordingly, only the 18 junction options for the predominantly southbound mainline widening option were modelled in Paramics. All options have however been subject to economic assessment, as there are cost differences for each of the mainline alignment options which result in different benefit cost ratios for each of the 54 options.
- 20.6.5. Similarly, some minor changes to the junction option layouts that were made during the assessment process have not been incorporated into the model networks; these would have insignificant impacts on model results.

Dalraddy to Slochd Model Extents

- 20.6.6. The impact of Dalraddy to Slochd dualling on traffic movements in the local area was assessed using the A9DTM12 S-Paramics model.
- 20.6.7. The area of model interest for the Dalraddy to Slochd scheme, within the overall A9DTM12 Paramics model network, is shown in **Figure 20-3**.

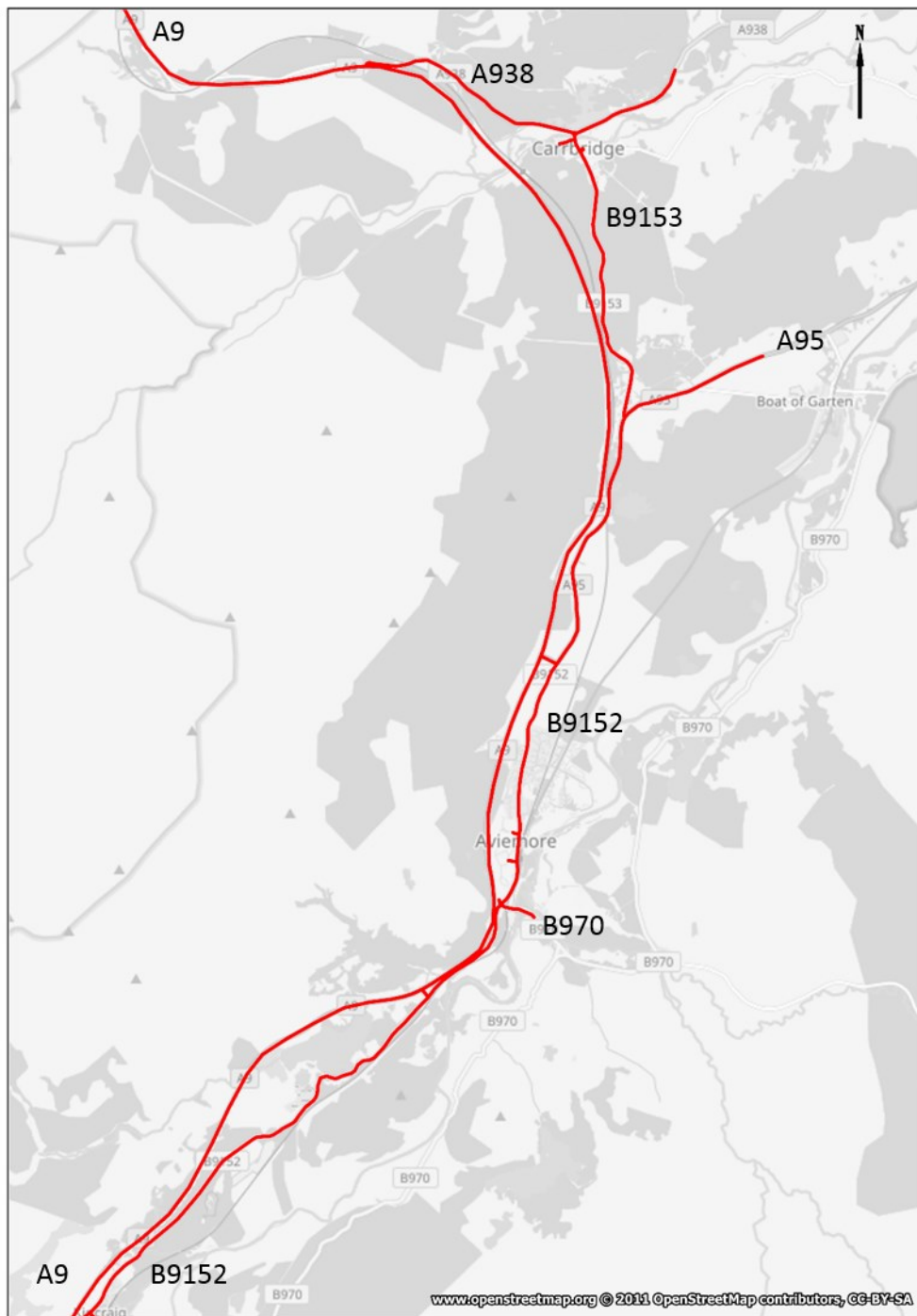

Figure 20-3 – Area of A9D2M Paramics Model Interest for Dalraddy to Slochd Scheme

Economic and Environmental Modelling Methodology

- 20.6.8. Guidance provided in the LTEA Technical Note 07 was used to set up the Do Minimum and Do Something Models for comparison in the economic assessment.
- 20.6.9. The economic assessment model and environmental assessment model differ in that for the economic assessment a fixed trip matrix, only incorporating traffic growth, is adopted; for the environmental assessment a variable trip matrix is adopted. The environmental assessment model uses revised demands for the future years to reflect

the wider impacts of the dualling of the A9 between Perth and Inverness in order to capture the maximum traffic impact of the upgraded route between Perth and Inverness, such as including existing trips that divert from other routes (outwith the model corridor) to the A9 (due it becoming a more attractive route).

- 20.6.10. In running the economic model, a number of parameters are adjusted to ensure consistency between the Do Minimum and the Do Something models (see LTEA Technical Note 07, Appendix B). This allows for a fairer economic assessment of the Do Something schemes by creating exactly the same demands (in terms of origin / destination trip pairs) in the model for each option, as is required for a fixed trip matrix assessment.
- 20.6.11. Four sets of demands were used in the running of the model. The morning period (07:00 till 10:00); the inter-peak period (10:00 till 16:00); the evening period (16:00 till 19:00) and the overnight period (19:00 till 07:00). The overnight period is used as a “warm up” and “cool down” before and after the assessment period of 07:00 to 19:00. The model was set up to generate the required output files for the economic and accident assessment calculations, following guidance provided in LTEA Technical Note 07.
- 20.6.12. The design years modelled were 2026 (first year of planned operation of the full A9 programme) and 2041, 15 years after opening.

Do Minimum Model

- 20.6.13. The Do Minimum model is defined as the standard A9DTM12 Do Minimum model. The Do Minimum network is assessed as it was in 2014 (i.e. before the introduction of the Average Speed Cameras) with the inclusion of highway schemes listed in Appendix A of LTEA Technical Note 07.

Do Something Models

Mainline Alignment

- 20.6.14. All of the 18 junction options with mainline Option 1 were assessed in the A9DTM12 model. For the purposes of traffic modelling, there is assumed to be no difference between these and the corresponding options with mainline Option 2 or Option 1a. For all 18 options, the modelled Do-Something network incorporates only the assessed scheme added to the Do Minimum network. This approach was adopted to ensure that the changes made in altering the model were fully consistent in the Do Minimum and Do Something models.

Junction Modelling

- 20.6.15. Each of the eight different junction layouts across the three junction locations were modelled and combined into the eighteen junction layout combinations. The junction layouts are shown below for the southbound widening option.
- 20.6.16. The three junction layout alternatives for the Aviemore South junctions are shown in **Figures 20-4 to 20-6**.

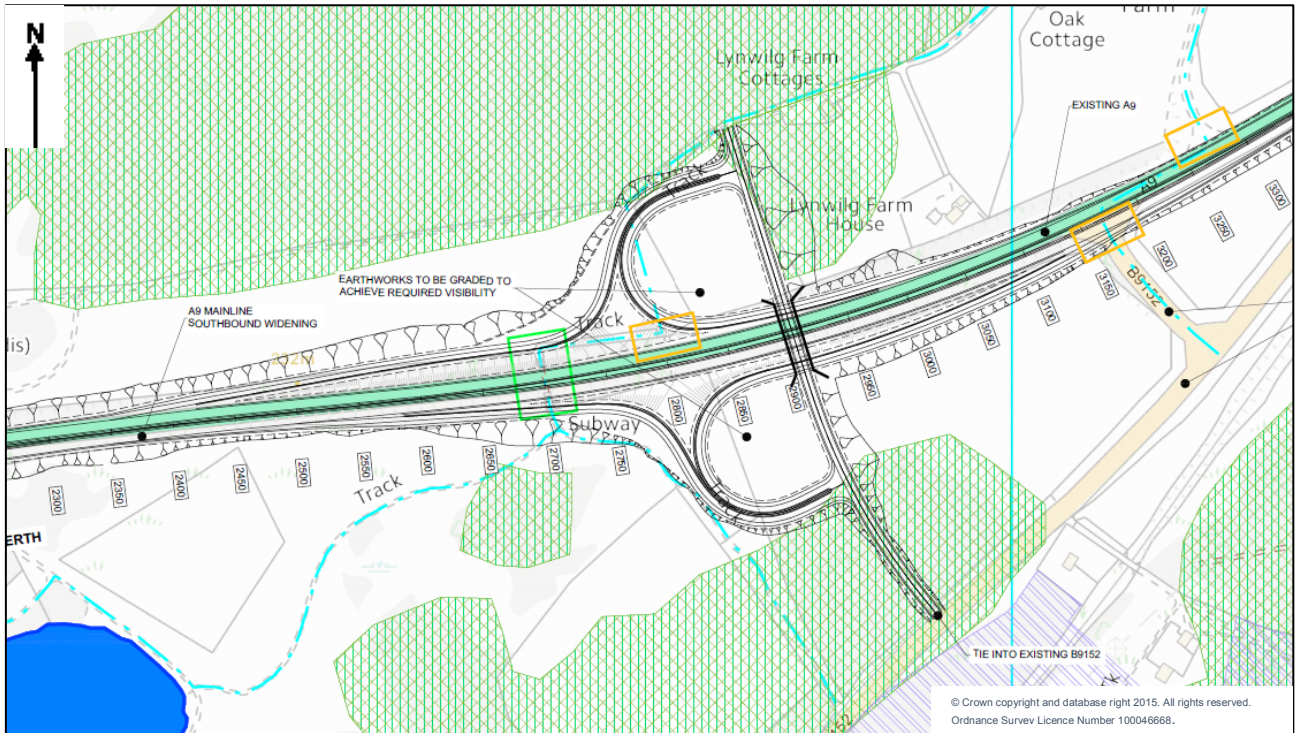

Figure 20-4 - Aviemore South - A02 - Half Cloverleaf Interchange (Quadrants 1 & 4)

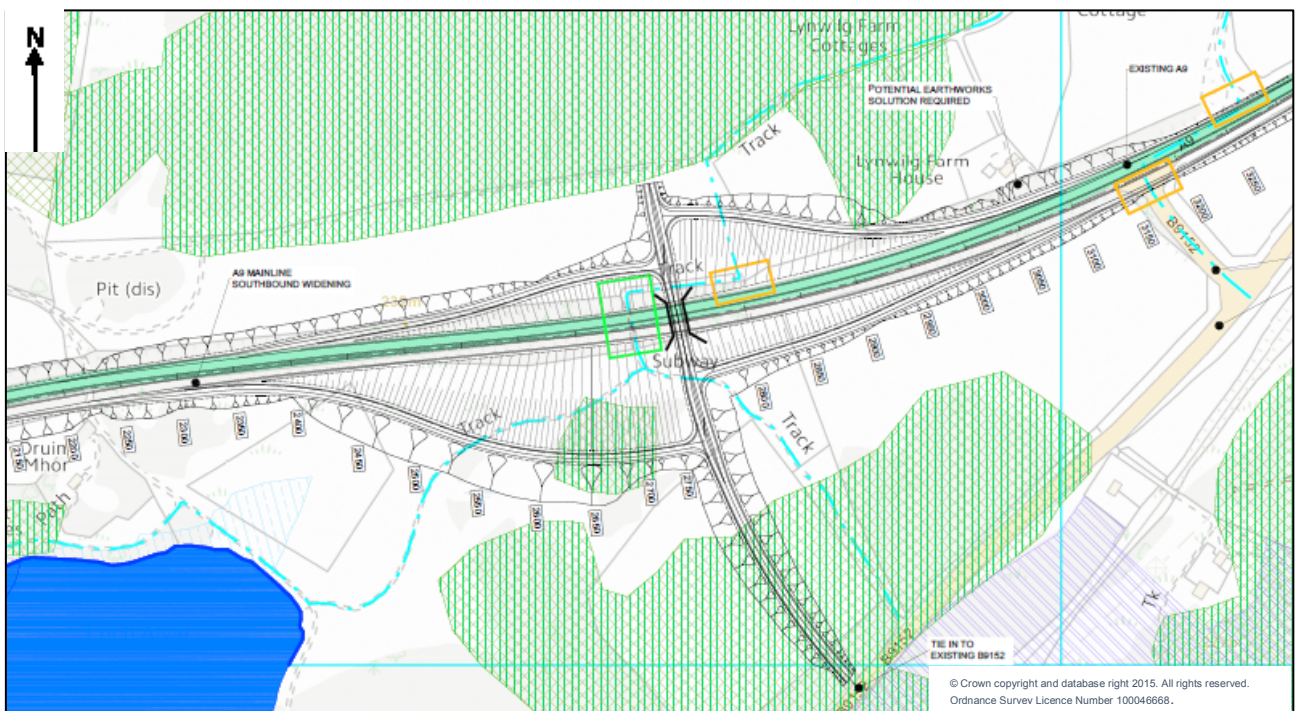

Figure 20-5 - Aviemore South - A09 Diamond Interchange (Left-Right Stagger & Ghost Island)



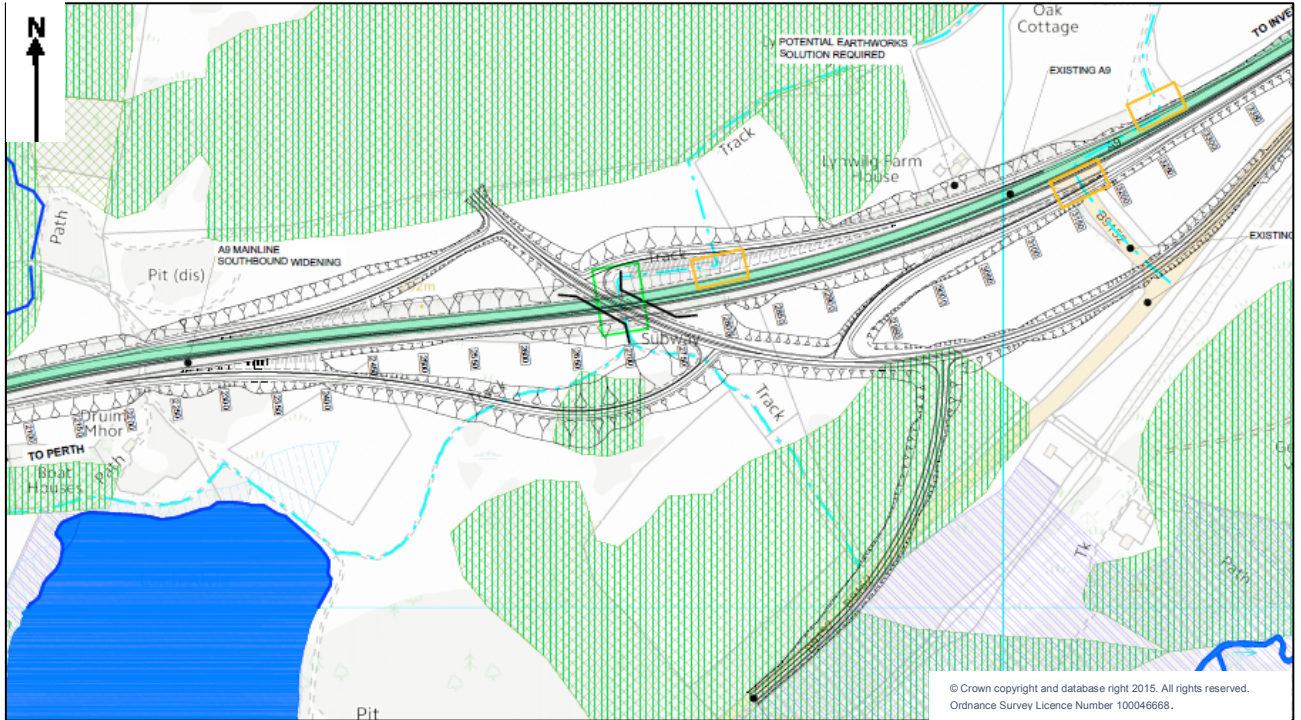

Figure 20-6 - Aviemore South - A18 – Diamond Interchange (B9152 Realigned)

20.6.17. The two junction layout alternatives for the Granish junctions are shown in **Figures 20-7 and 20-8** below.

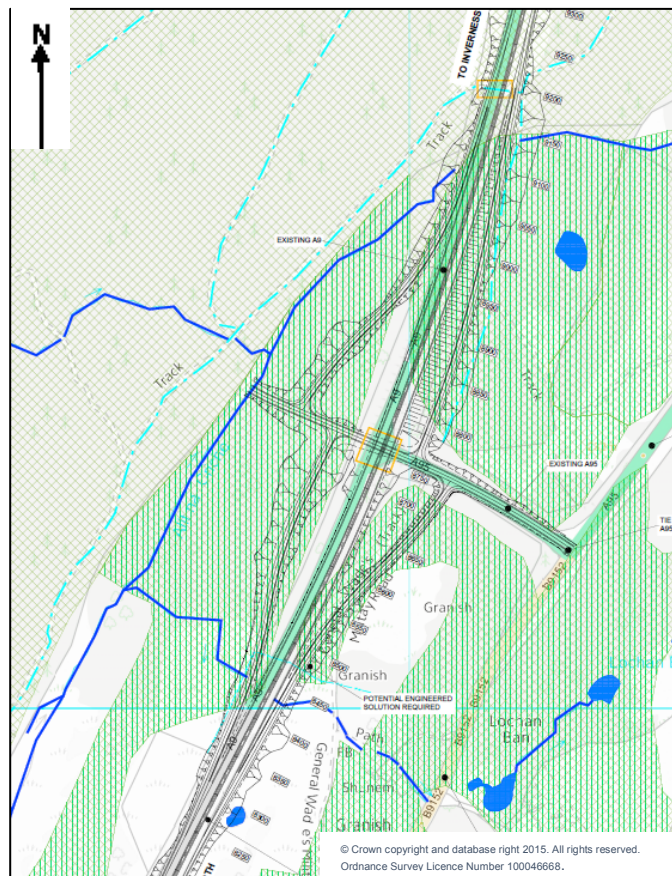

Figure 20-7 – Granish - C31 - Diamond Interchange (Left-Right Stagger)



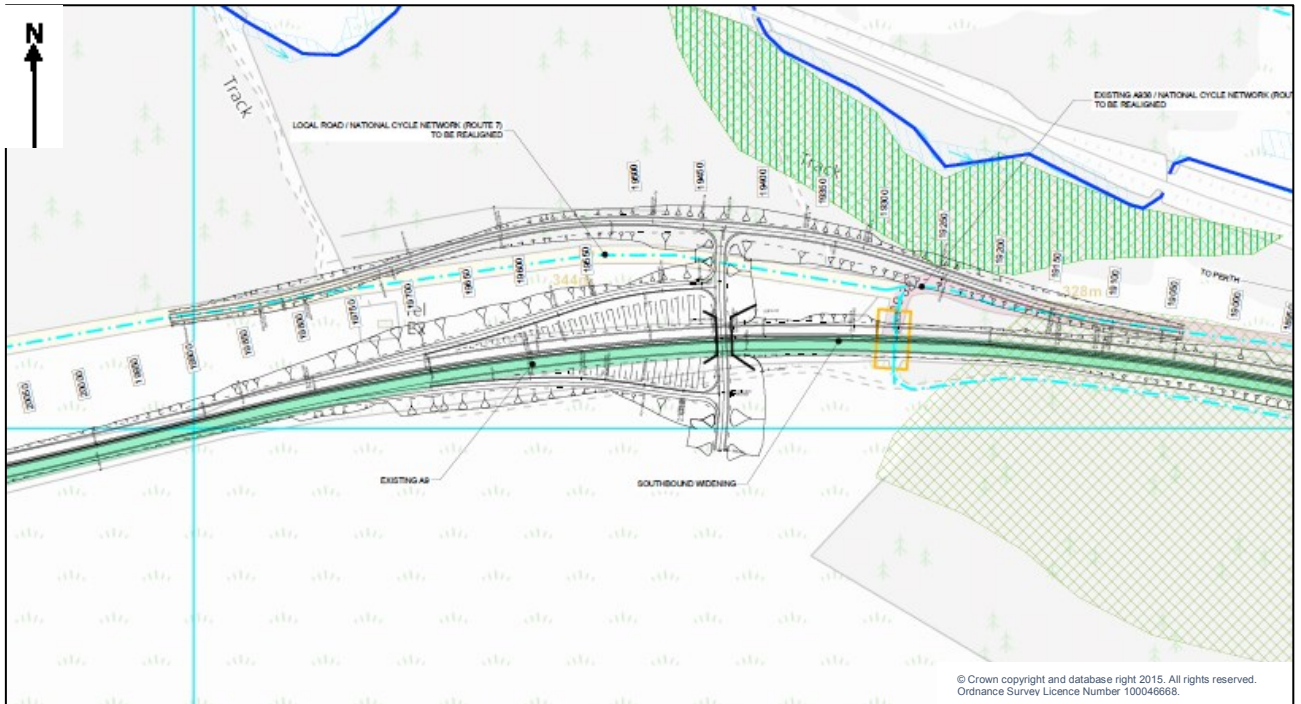

Figure 20-10 - Black Mount - D03 - Half Diamond (Restricted Access with North-facing Slips)

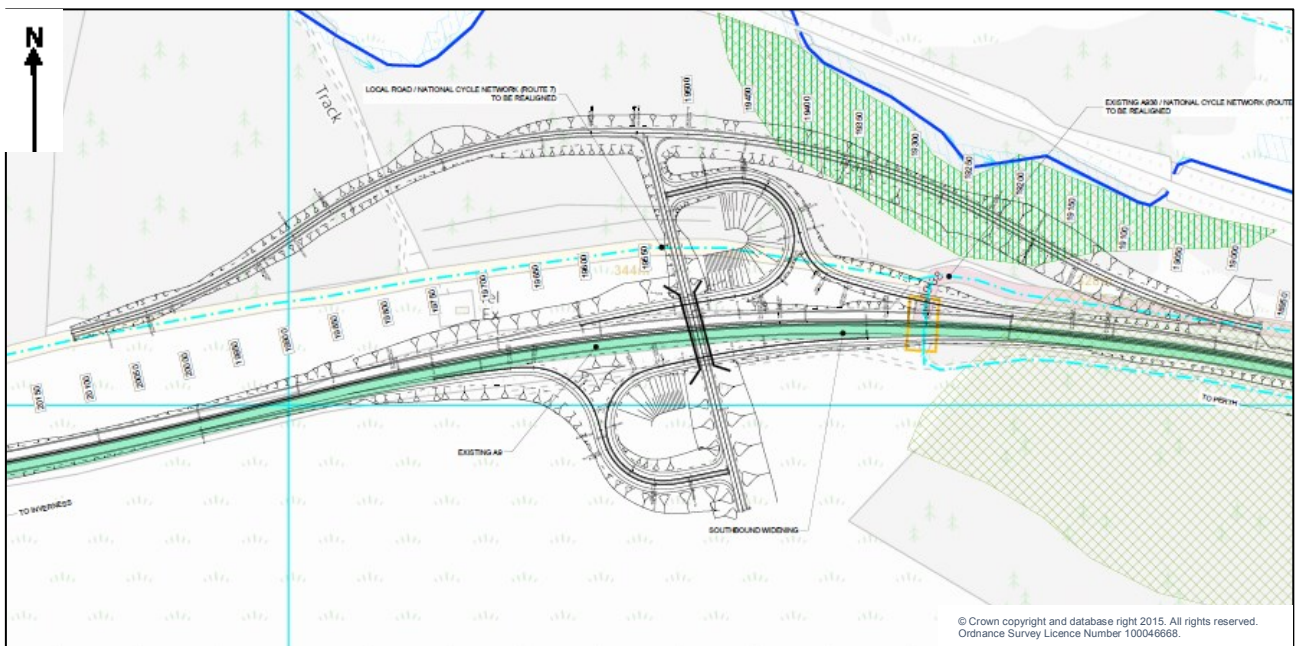

Figure 20-11 - Black Mount - D51 - Half Cloverleaf (Quadrants 2 & 4)

Modelled Traffic Flows

20.6.19. The modelled traffic flows from the A9DTM12 modelling are shown in the following figures. **Figures 20-12 to 20-14** show the flows for 2026 the opening year and **Figures 20-15 to 20-17** show the flows for 2041, 15 years after opening. Modelled flows for six of the 18 options are compared with Do Minimum flows in each of the diagrams.



2026 Opening Year Traffic Flows

- 20.6.20. The 2026 link flows show that the dualling of the A9 attracts additional traffic compared to the Do Minimum situation. The additional traffic joins and leaves the A9 via the Granish and Black Mount junctions and mostly affects the A95 and A938 routes to and from the east. The levels of traffic using the B9152 through Aviemore and south of the Aviemore South junction are generally similar across all options and differ little from the Do Minimum.
- 20.6.21. Notwithstanding increased levels of traffic predicted to use the A9 at Granish, and to a lesser extent Black Mount, to access the A95 and A938 after dualling, total through traffic on the A9 is increased in both directions when comparing Do Minimum and the 18 Option scenarios. Through traffic with the A9 dualling options, north of the Black Mount junction, is predicted to be approximately 600 vehicles per day higher in both the southbound and northbound directions.
- 20.6.22. The dualling of the A9 does however appear to have a small effect on the junctions used by Aviemore traffic. Traffic between Aviemore and Granish is slightly higher in all options compared to the Do Minimum, while traffic south from Aviemore to the A9 seems to be slightly lower in the options compared to the Do Minimum scenario. This is likely to be due to traffic travelling between the northern end of Aviemore and the south finding it more attractive to stay on the dual carriageway route to Granish and to then travel southwards into Aviemore. This route is not attractive at present due to the Aviemore Bypass being single carriageway with limited overtaking opportunities.
- 20.6.23. The Black Mount junction is only used by a low level of traffic to and from the south; only approximately 100 vehicles daily turn onto the A9 southbound at this junction in options where south facing slip roads are provided. In the northbound direction, for two options only 3 vehicles uses the Black Mount junction to reach the A938, while in many options no traffic at all is modelled using this slip road. The difference in use of Black Mount in the two directions is expected to be due to inherent modelling assumptions, however 100 -200 vehicles / day is considered to be a reasonable indication of the level of traffic demand between the A9 south and the A938. Given that the main destination reached from Black Mount is Carrbridge which lies to the south it is clear that the preferred route for traffic to and from the south is via Granish / A95 / B9153.

2041 Design Year Traffic Flows

- 20.6.24. The 2041 modelled design year traffic flows from the A9DTM12 modelling are shown in the figures overleaf. Modelled flows for six of the 18 options are compared with Do Minimum flows in each of the three diagrams.
- 20.6.25. The 2041 traffic patterns predicted by the A9DTM12 modelling are broadly similar to those in the 2026 model year, with A9 through traffic significantly increased in both directions and more traffic accessing the A95 at Granish.
- 20.6.26. The magnitude of traffic flow in the 2041 model is significantly greater than that in 2026, due mainly to 15 years of traffic growth, however these differences vary. For the mainline through traffic flows along the A9, 2041 traffic is predicted to be approximately 800 vehicles greater per day in each direction, compared to 2026; around the Aviemore local road network, the design year flows increase by fewer than 200 vehicles.

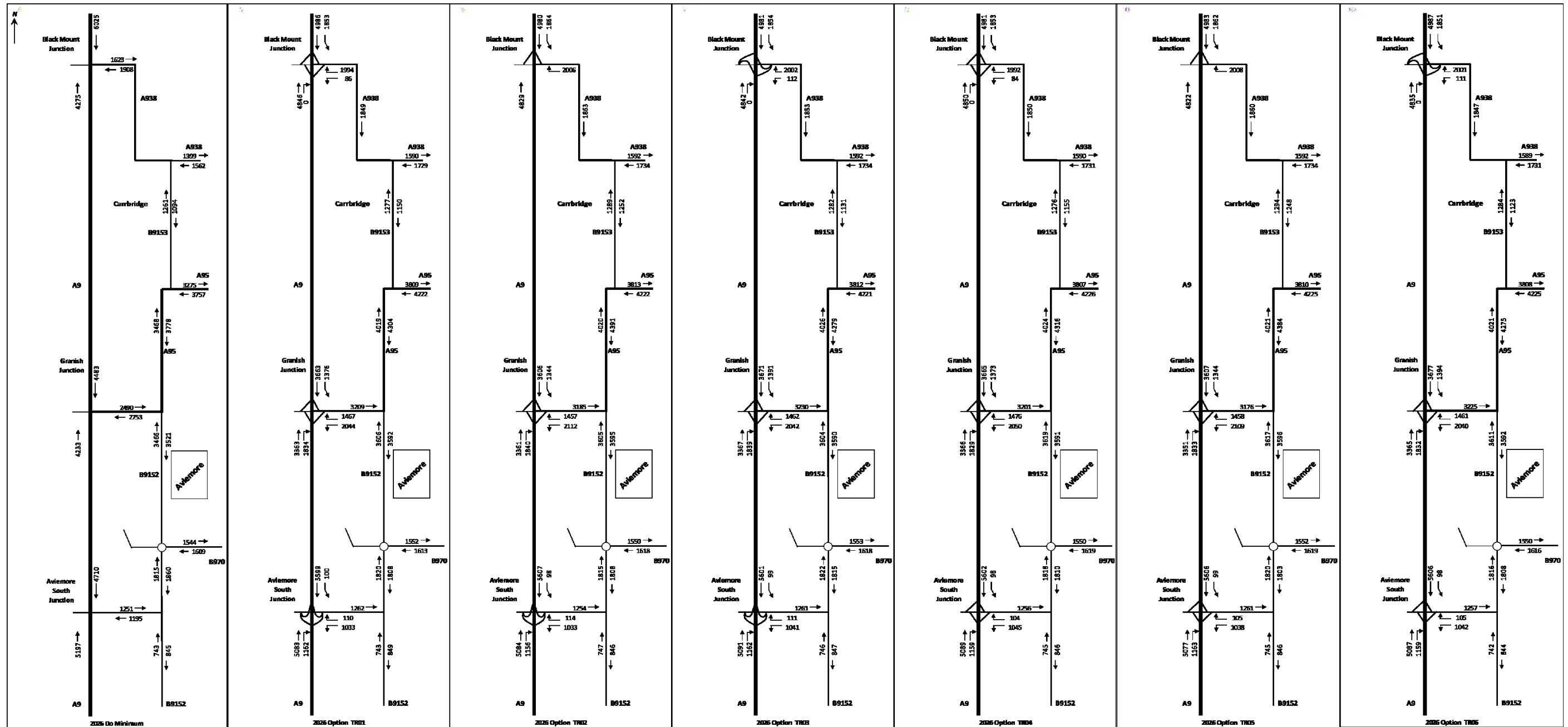

Note: Modelled traffic flows shown are for weekdays from 07:00 to 19:00

Figure 20-12 Comparison of 2026 Modelled Dalraddy to Slochd Traffic Flows for Do Minimum and Options TR01 to TR06



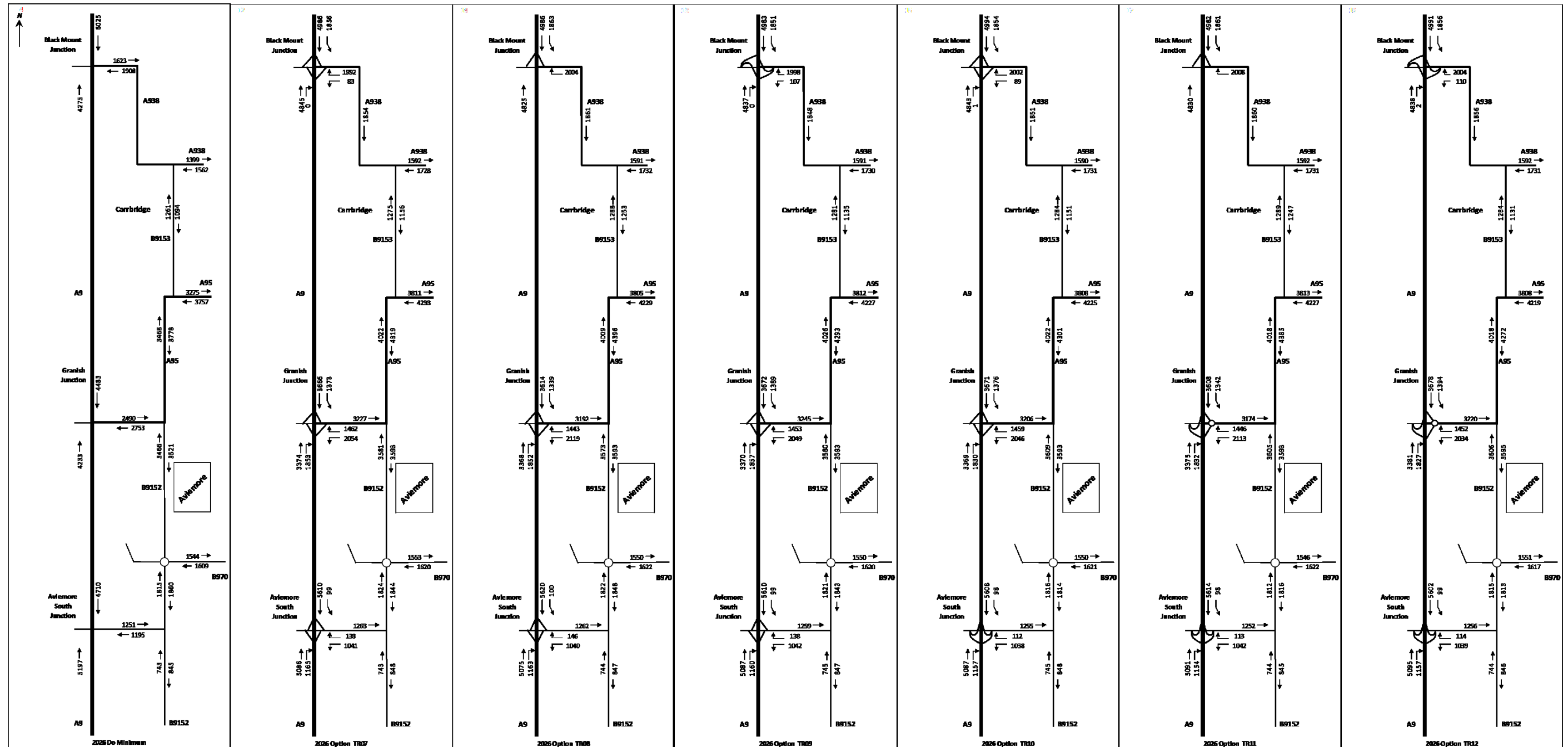

Note: Modelled traffic flows shown are for weekdays from 07:00 to 19:00

Figure 20-13 Comparison of 2026 Modelled Dalraddy to Slochd Traffic Flows for Do Minimum and Options TR07 to TR12



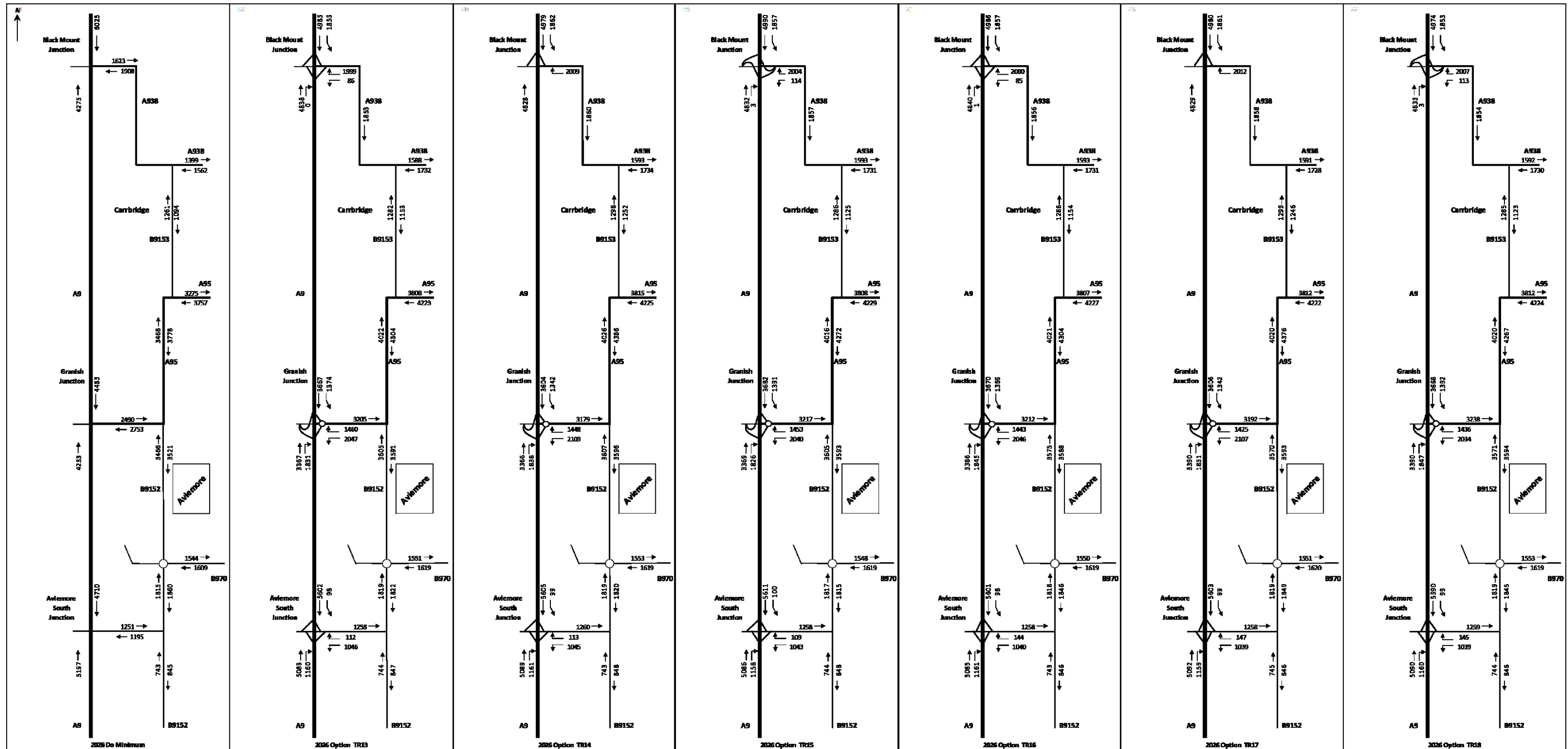

Note: Modelled traffic flows shown are for weekdays from 07:00 to 19:00

Figure 20-14 Comparison of 2026 Modelled Dalraddy to Slochd Traffic Flows for Do Minimum and Options TR13 to TR18



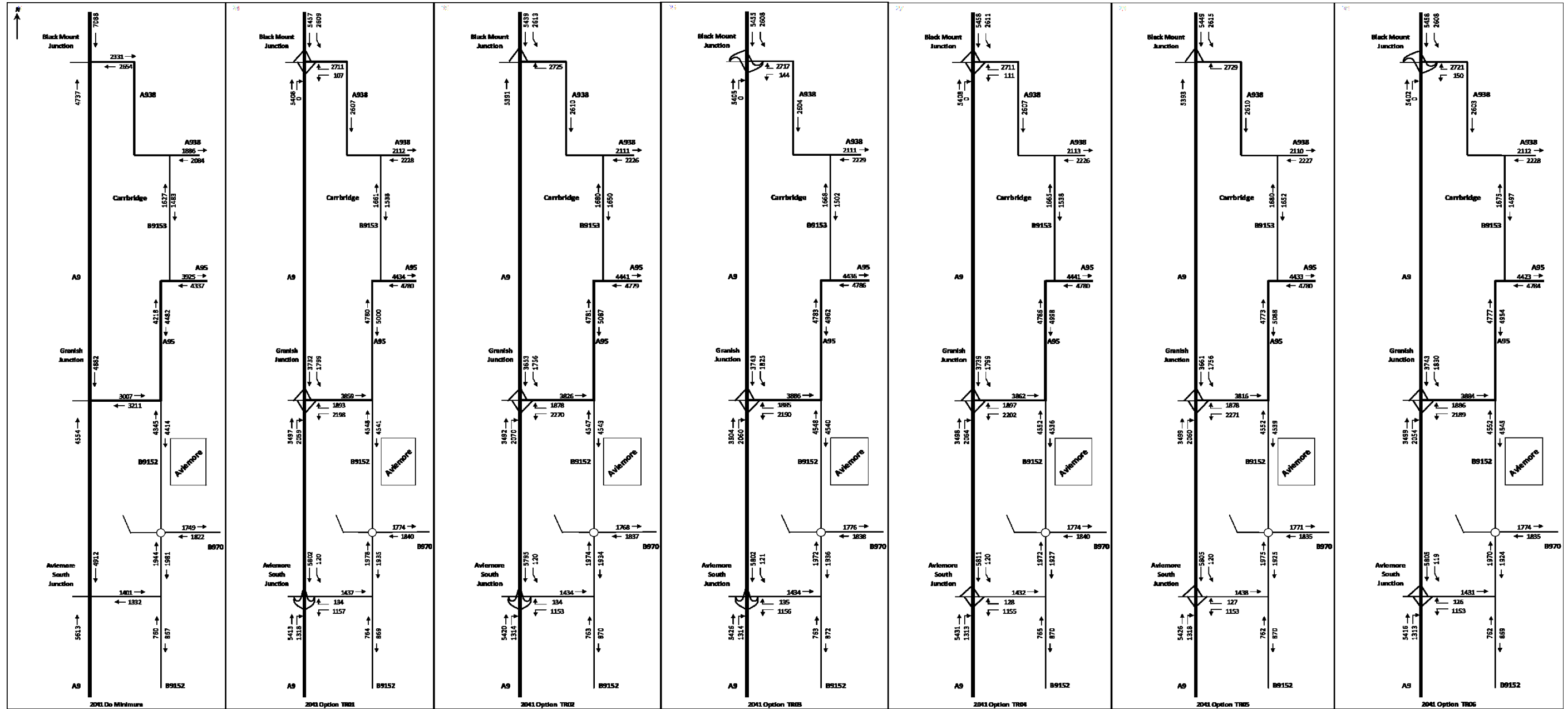

Note: Modelled traffic flows shown are for weekdays from 07:00 to 19:00

Figure 20-15 Comparison of 2041 Modelled Dalraddy to Slochd Traffic Flows for Do Minimum and Options TR01 to TR06



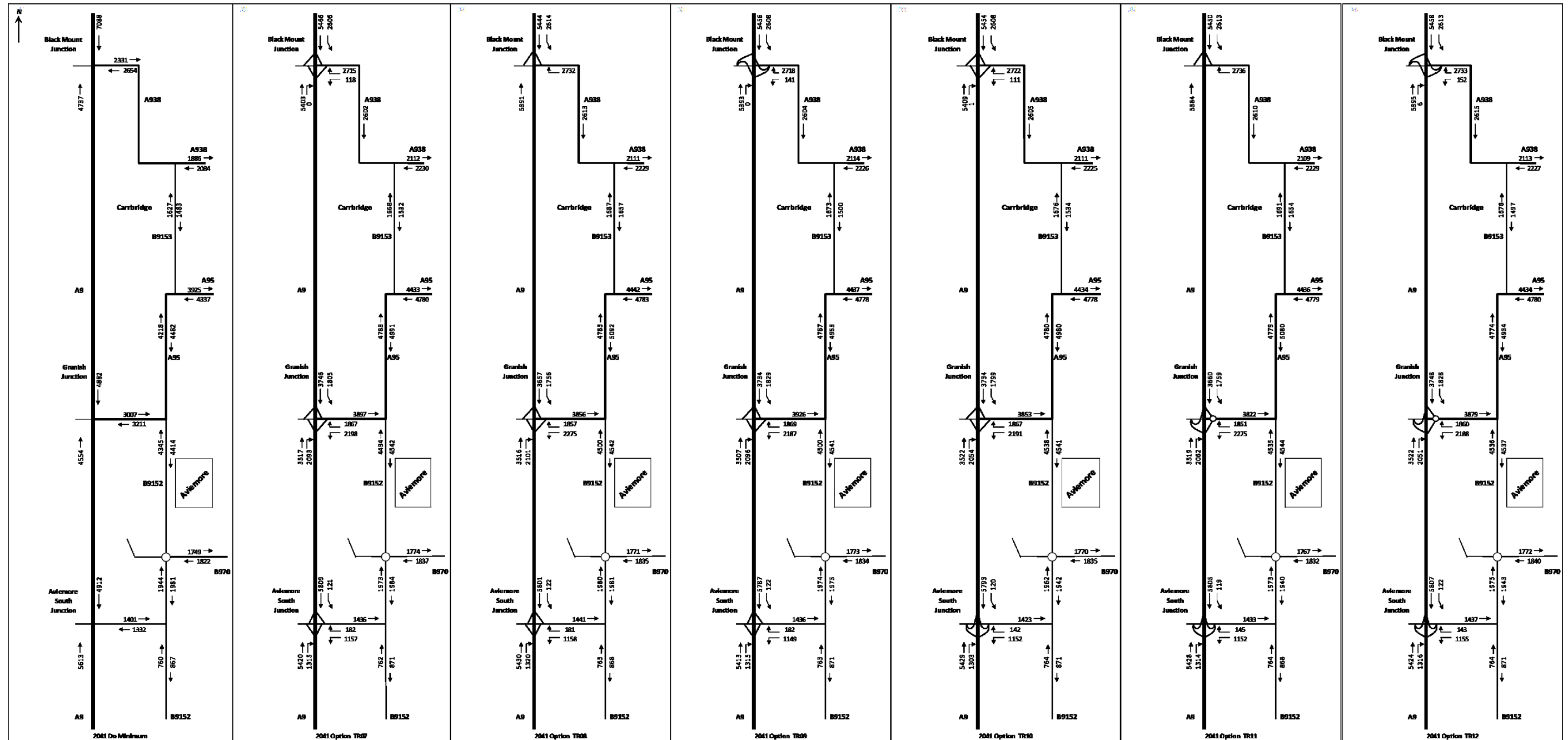

Note: Modelled traffic flows shown are for weekdays from 07:00 to 19:00

Figure 20-16 Comparison of 2041 Modelled Dalraddy to Slochd Traffic Flows for Do Minimum and Options TR07 to TR12



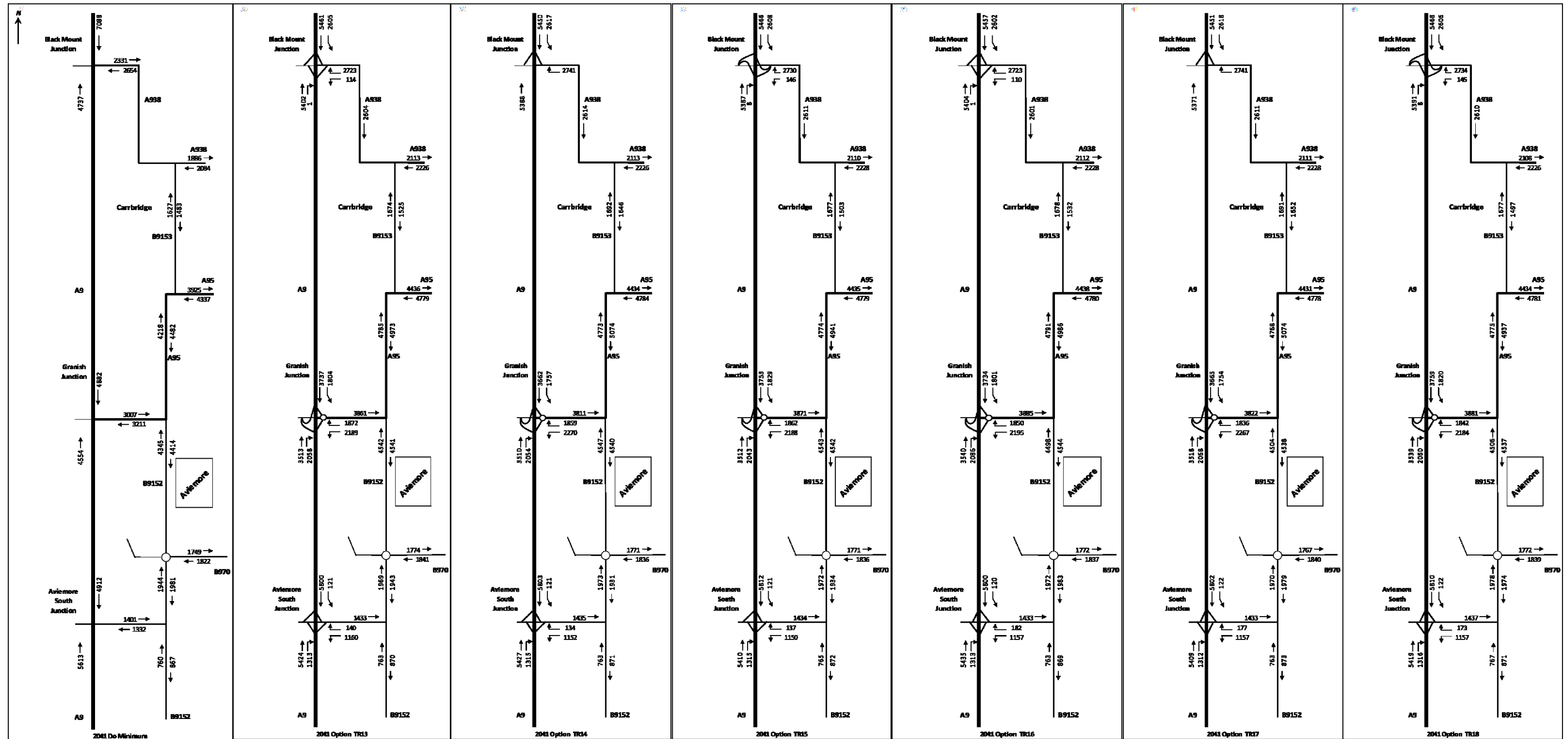

Note: Modelled traffic flows shown are for weekdays from 07:00 to 19:00

Figure 20-17 Comparison of 2041 Modelled Dalraddy to Slochd Traffic Flows for Do Minimum and Options TR13 to TR18



21. Economic Appraisal

21.1. Introduction

21.1.1. The economic appraisal of the A9 Dalraddy to Slochd route options has been carried out using the Department for Transport's (DfT) TUBA program (version 1.9.5), which was developed for transport scheme appraisal. Accident analysis for the options has been undertaken using the 'A9 Accident & Cost Processor Rev06' provided by SIAS.

21.2. Method of Appraisal

21.2.1. The TUBA software requires the following data inputs for the Do Minimum and Do Something scenarios for one hour time slices from 0700 to 1900 for each zone to zone movement:

- Trips;
- Journey times; and
- Journey distances.

21.2.2. TUBA parameters are defined at programme level and are summarised in Appendix B of LTEA Technical Note 07. The current year for TUBA assessment is set as 2015 with opening and horizon years of 2026 and 2041 respectively.

21.2.3. Model data was extracted from the Dalraddy to Slochd A9DTM12 models described in the previous chapter. Data from the models for all 18 variations of Mainline Option 1 was used for the corresponding Option 2 and Option 1a TUBA assessments. Only the scheme cost data changed between the three mainline options since the variations in mainline alignments were too small to change route assignment, journey times or distances.

21.2.4. Transport modelling for the economic appraisal is different to that used for engineering design purposes and environmental appraisal, as discussed in the previous section.

21.2.5. In accordance with HM Treasury Green Book and DMRB guidance, the benefit stream for the project is calculated for a 60 year period. This has been assumed to be 2026 to 2085, based on a year of opening of 2026. The process includes indexation and adjustments for inflation to ensure consistency.

21.2.6. The benefits calculated by TUBA and the scheme accident analysis have been used to calculate the overall Benefit to Cost Ratio (BCR) for the Dalraddy to Slochd scheme options.

- 21.2.7. TUBA produces a number of indicators which are used to assess scheme benefits and calculate the BCR, these are listed below.
- Present Value of Benefits (PVB);
 - Present Values of Costs (PVC);
 - Net Present Value (NPV) = PVB – PVC; and
 - Benefit to Cost Ratio (BCR) = PVB/PVC.
- 21.2.8. The BCR for the Dalraddy to Slochd section options of the A9 dualling scheme is used only to rank options against one another, since the overall scheme BCR is only applicable at an A9 Dualling Programme level due to additional benefits accrued from completion of the full dualling from Perth to Inverness. BCRs for Dalraddy to Slochd are thus expressed as indexed values, with the highest BCR having an index of 100.
- 21.2.9. As the BCR is only calculated for purposes of comparison of the alignment options, the ranking of BCRs will be used to help determine which option will be taken forward to Stage 3 as the preferred option.
- 21.2.10. Inputs to the accident analysis tool are link based; each link being assigned a length, type, speed limit and AADT flow. Do Minimum accident analysis uses local accident and severity rates while for Do Something models, national rates are used. Further guidance on the process is provided in Appendix C of LTEA Technical Note 07 and derivation of the input data is detailed in LTEA Technical Note 04 (“Local Safety Parameters”).
- 21.2.11. For the Do Something models Technical Note 07 sets down that the settings for the processor are to be as follows (NB: the processor defaults to these settings if a Do Something scheme is selected):
- July 2014 NESA values (DMRV Vol. 15);
 - A flow range for the processor of “AADT_Flow_00_24”;
 - An annualisation factor of 365 to factor the AADT data to a yearly average;
 - Linear interpolation to be adopted undertaken between 2026 and 2041 for the years 2027 to 2040; and
 - The 2041 values were used for all years between 2042 and 2085.

21.3. Construction & Maintenance Costs

Construction Cost Estimates

- 21.3.1. For the purposes of this Stage 2 economic assessment for Dalraddy to Slochd, construction of the scheme is assumed to be completed in 2025, with the capital expenditure assumed to occur in 2022 – 25 and with pre-construction costs incurred before that. At programme level it has been agreed that all schemes are treated equally by scheduling completion in 2025. The actual phasing of the individual schemes will be assessed at programme level in the Cfl.
- 21.3.2. The estimated costs for the scheme (most likely costs, including inflation) range from £613.2m for Junction Option TR12 with Mainline Option 1 to £660.5m for Junction Option TR13 with Mainline Option 2. These costs include risk and optimism bias (see below). In terms of alignment, Alignment 1 is generally the lowest cost, with Alignment 1a marginally more expensive and Alignment 2 the most expensive. Those options with



restricted movements at Black Mount are marginally less expensive than those allowing full movements at this location.

Programme and Project Risk

- 21.3.3. Transport Scotland has developed a quantified risk assessment proforma to consider risk and opportunity across the A9 dualling programme. This approach has been applied at programme level to those risks and opportunities that are best managed at a programme level and at a project level to risks and opportunities that may be present within individual projects.
- 21.3.4. Transport Scotland's methodology ("A9 Dualling Programme – Guidance on Risk & Opportunity Management" issued by Transport Scotland) considers the potential cost/benefit to the project of each risk/opportunity, how likely they are to occur and how these can be mitigated. The methodology was applied by the design team during regular workshops representing all the major disciplines involved on the project. Key to this process were regular reviews to update the registers and hence to provide increased confidence in the cost estimate as the project progresses.

Optimism Bias

- 21.3.5. Optimism bias is added to the construction costs as a check on underestimating the construction cost estimates and improving confidence that outturn construction costs will not exceed these estimates. As the design is developed and refined, the optimum bias can be reduced to reflect increasing cost certainty.
- 21.3.6. The optimism bias for this scheme has been calculated using Transport Scotland's A9 Dualling Optimism Bias Adjustment Template spreadsheet. The most likely optimism bias at this stage has been calculated at 22%. Refer to Part 1, Section 3.2.8 for further details.

Maintenance Costs

- 21.3.7. In addition to construction costs, an assessment of maintenance costs has been made for the Do Minimum and Do Something options.
- 21.3.8. Maintenance costs for the Do Minimum include:
- Full pavement renewals at 20 year intervals (3 over 60 year period);
 - Joint and parapet replacement; and
 - Ancillary maintenance and replacement.
- 21.3.9. Maintenance costs for the Do Something options include only two pavement renewals during the 60 year appraisal period, since the completed scheme will have a new pavement from the outset. Maintenance costs for the three mainline alignment options were assumed to be the same.

Exclusions

- 21.3.10. No assessment of construction or maintenance delays has been carried out. This is consistent with appraisal of the other sections of the A9 dualling programme and reflects the fact that such delays will not be a key differentiator between very similar on-line schemes at this stage in their development.



21.4. Accidents

- 21.4.1. The cost of accidents has been assessed for each option using the A9 Accident and Cost Processor software. Accident costs for each of the eighteen junction options were compared against the Do Minimum; it was assumed that the accidents relating to the three alignment options would be identical.
- 21.4.2. The A9 Accident and Cost Processor accident tool calculates the number of accidents that would occur in the Do Minimum and Do Something scenarios using measured rates for the Do Minimum and using default 2014 NESA accident rates for each road class for the Do Something. This is the approach recommended in DMRB Vol. 15 and may result in an over or under estimation in the number and type of accidents saved, between the various options assessed, however the estimates will be consistent and this is unlikely to significantly affect the overall comparison of accident costs relative to each other.
- 21.4.3. The processor accident tool calculates the number of fatal, serious and slight accidents that would occur on each link using the accident rates and the traffic flows in each scenario. The difference between each scenario is calculated and presented as the accident benefit, or disbenefit. The A9 Accident and Cost Processor accident tool also generates estimates of casualties that will be saved over the 60 year assessment period for each of the three accident severities; this can then be monetised and expressed as an annual saving or cost.
- 21.4.4. The predicted accident savings over the 60 year assessment period are summarised in terms of financial savings. All options produce accident savings relative to the Do Minimum scenario.
- 21.4.5. The predicted accident savings shown in **Table 21-1** demonstrate that the process is predicting very similar levels of accident savings between the 18 assessed options. This conforms to expectations, as all options eliminate all at-grade right turning movements and provide a similar high quality route in the future.

Table 21-1 Indexed Predicted Accident Savings

Junction Layout	Fatal	Serious*	Slight*
TR01	99.57%	88.05%	98.51%
TR02	99.32%	79.21%	96.87%
TR03	99.82%	93.88%	99.16%
TR04	99.59%	85.19%	97.48%
TR05	99.34%	76.82%	95.93%
TR06	99.83%	91.04%	98.19%
TR07	99.74%	94.01%	99.32%
TR08	99.51%	85.93%	97.76%
TR09	100.00%	100.00%	100.00%
TR10	99.55%	86.31%	97.90%
TR11	99.31%	78.09%	96.33%
TR12	99.79%	92.00%	98.57%
TR13	99.57%	83.81%	96.96%
TR14	99.32%	75.27%	95.34%
TR15	99.82%	89.73%	97.63%
TR16	99.74%	92.66%	98.74%
TR17	99.48%	83.93%	97.11%
TR18	99.96%	97.96%	99.36%

* Due to methodology used, serious and slight accidents are predicted to increase as explained below.

- 21.4.6. It should be noted that the recorded serious and slight accident rates, which the Do Minimum is subject to, are significantly lower than the NESAs national accident rate, and therefore slight accidents are predicted to increase on the scheme. The Do Minimum accident severities are however significantly higher than the NESAs national accident severities. The accident analysis will be updated for the Stage 3 assessment.

21.5. Results of Economic Assessment

- 21.5.1. The analysis of the Case for Investment for the entire A9 dualling project is subject to ongoing refinement by Transport Scotland’s programme level consultants, who will update their analysis as and when required to inform the investment decisions.
- 21.5.2. The purpose of this economic assessment, at this Stage 2 DMRB report level, is to identify the best value alignment and junction options for Dalraddy to Slochd. For this reason, the reporting of the results of the assessment shows only the ranking of each option for each economic criteria and the overall ranking.

Benefits

- 21.5.3. The ‘Present Value Benefits’ ranking, ‘Accident Benefits’ ranking and ‘Total Present Value Benefits’ are the same for the Option 1, Option 2 and Option 1a mainline alignments, as the same data has been used for all three alignments. The relative performance of the various junction layout options is summarised in **Table 21-2**.
- 21.5.4. From **Table 21-2** it can be seen that based on the benefits calculated in TUBA Option TR03 performs best, with Option TR09 the next best option. Combining the TUBA and accident benefits with the accident benefits shows that junction option TR03 has the highest level of benefits, followed by TR09, with TR06 third. It is notable that these three options all have restricted movements at Black Mount.

Table 21-2 Summary of Benefits - All Mainline Options

Junction Layout	Present Value Benefits (PVB) (TUBA)	Present Value Accident Benefits	Total Present Value of Benefits
TR01	95.16%	99.24%	96.05%
TR02	90.53%	98.67%	92.25%
TR03	100.00%	99.64%	100.00%
TR04	94.97%	99.09%	95.88%
TR05	89.14%	98.54%	91.11%
TR06	97.57%	99.49%	98.03%
TR07	96.34%	99.59%	97.07%
TR08	91.93%	99.05%	93.44%
TR09	97.54%	100.00%	98.11%
TR10	89.14%	99.11%	91.23%
TR11	87.10%	98.57%	89.49%
TR12	94.99%	99.50%	95.98%
TR13	88.73%	98.96%	90.87%
TR14	86.15%	98.41%	88.70%
TR15	91.69%	99.38%	93.32%
TR16	91.67%	99.48%	93.32%
TR17	88.33%	98.90%	90.54%
TR18	96.44%	99.84%	97.20%

21.6. Summary

21.6.1. In **Table 21-3** the Present Value of Costs (PVC) of the scheme options are presented alongside the Net Present Value (NPV) and the Benefit Cost Ratio (BCR). The NPV is the total benefits of the scheme less the total scheme costs and shows the overall scheme which generates the most value. The BCR considers the ratio of the benefits to the costs and is more commonly used to compare schemes.

Table 21-3 Comparison of Costs and Net Present Values for All Mainline Options

Junction Layout	Mainline Alignment Option 1			Mainline Alignment Option 2			Mainline Alignment Option 1a		
	Present Value Costs (PVC)	Net Present Value (NPV)	Final BCR Ranking	Present Value Costs (PVC)	Net Present Value (NPV)	Final BCR Ranking	Present Value Costs (PVC)	Net Present Value (NPV)	Final BCR Ranking
TR01	97.8%	96.6%	93.7%	94.9%	93.0%	91.1%	97.1%	95.8%	93.1%
TR02	98.5%	96.3%	89.7%	95.6%	92.7%	87.3%	97.8%	95.5%	89.1%
TR03	99.4%	100.0%	100.0%	95.9%	95.6%	96.6%	98.7%	99.2%	99.4%
TR04	95.6%	93.9%	91.5%	92.7%	90.2%	89.1%	95.0%	93.0%	91.0%
TR05	96.3%	93.2%	86.5%	93.5%	89.6%	84.2%	95.7%	92.3%	86.0%
TR06	97.2%	96.6%	95.5%	93.7%	92.2%	92.4%	96.6%	95.8%	94.9%
TR07	96.3%	95.1%	93.5%	93.4%	91.4%	90.9%	95.7%	94.3%	92.9%
TR08	97.0%	94.8%	89.8%	94.1%	91.2%	87.4%	96.4%	94.0%	89.2%
TR09	97.9%	97.5%	96.1%	94.4%	93.0%	92.9%	97.3%	96.6%	95.5%
TR10	98.4%	95.8%	88.3%	94.7%	91.1%	85.1%	97.7%	95.0%	87.7%
TR11	99.1%	96.1%	86.8%	95.4%	91.5%	83.8%	98.5%	95.3%	86.3%
TR12	100.0%	99.4%	95.6%	95.7%	93.9%	91.6%	99.4%	98.6%	95.0%
TR13	96.2%	92.9%	86.0%	92.5%	88.2%	83.0%	95.6%	92.1%	85.5%
TR14	96.9%	93.1%	84.1%	93.3%	88.5%	81.2%	96.3%	92.3%	83.6%
TR15	97.8%	95.8%	90.3%	93.5%	90.3%	86.6%	97.2%	95.0%	89.7%
TR16	96.9%	94.6%	89.5%	93.2%	89.9%	86.3%	96.3%	93.8%	88.9%
TR17	97.6%	94.6%	86.8%	93.9%	89.9%	83.8%	97.0%	93.8%	86.2%
TR18	98.5%	97.9%	95.6%	94.2%	92.5%	91.7%	97.9%	97.1%	95.0%

Benefit Cost Ratio

21.6.2. Using the BCR to combine the costs and the benefits shows that the best performing option is junction layout TR03 with Alignment 1, followed very closely by junction layout TR03 with Alignment 1a (just over 0.5% poorer performance). Next is junction layout TR09 with Alignment 1, but this has almost 4% poorer performance.

21.6.3. The three worst performing options are junction layouts TR14, TR13 and TR 17 all with Alignment 2. Their performance is between 16% and 19% poorer than the best performing option.

21.6.4. At this stage some preliminary conclusions can be drawn from the economic performance data:

- Alignment Option 1 performs best;
- Alignment Option 1a is next best;
- Options with restricted movements at Black Mount perform better than other options. This reflects the small disbenefit arising due to the limited demand for the south facing slip roads and the cost savings arising from their elimination; and
- Options with a diamond junction at Aviemore South perform worse than other options.

Net Present Value

21.6.5. Whilst the use of NPV to rank the options is a sound approach, it should also be noted that the NPV of the poorest performing options are within 19% of that of the highest performing option. As it is quite feasible that other considerations could affect the decision regarding which option to take forward to Stage 3, this analysis suggests that the scheme economics are not particularly sensitive to traffic impacts.

Conclusion

21.6.6. In conclusion there is no particularly compelling economic case for a particular option. Cost is clearly an issue but more expensive schemes do not deliver significant extra benefits nor do less costly schemes have major dis-benefits. This is in line with expectations as traffic levels are generally low and no congestion is expected. Accordingly economics is unlikely to be a significant determinant for option selection, although cost and affordability are clearly important.

